

# Air Force Civil Engineer Center

---



## Pease RAB Meeting

27 June 2018



# Agenda

---

- **Welcome and Introduction** – Ona Ferguson
  - Approve summary from March 2018 RAB meeting.
  - Membership update.
  - RAB contact list.
- **Site 8 Visit Follow Up** – Roger Walton
  - Review and discuss RAB site visit
- **Pease PFAS Risk Screening** – Amy Quinton
  - Exposure assessment
- **PFAS Resources** – Roger Walton
  - Overview of existing reference documents and reports.
- **Portsmouth Water Treatment** – Brian Goetz (City of Portsmouth)
  - Brief update on water treatment activities.
- **Public Comments**
  - Members of the general public may request up to 3 minutes to speak.
- **Meeting recap, upcoming meeting date** – Ona Ferguson
- **Adjourn**



# RAB Member Administrative Items

---

- Approve summary from March 2018 RAB meeting
- Membership update
- RAB contact list



# Pease Sites Map

As of 2017

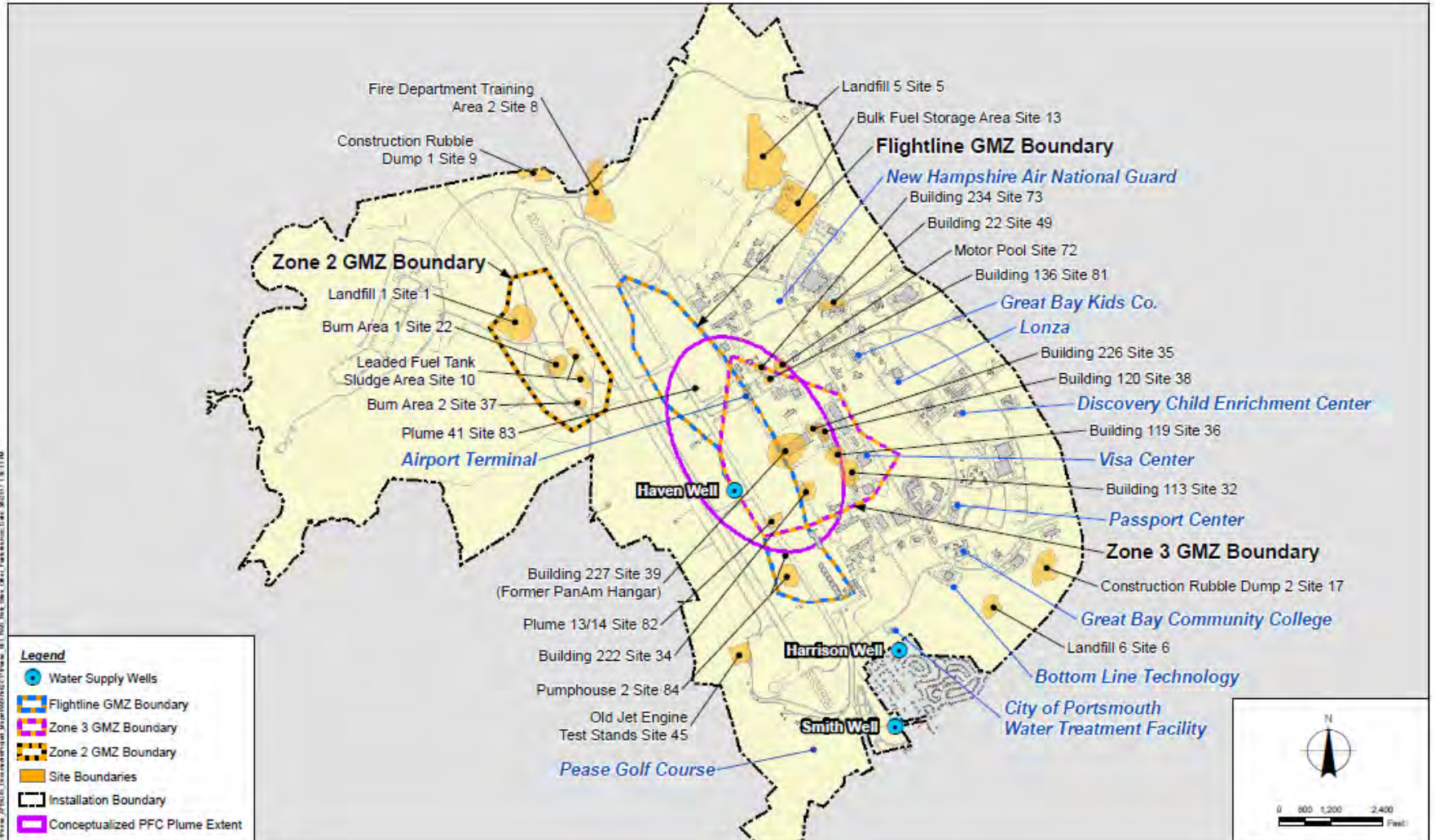

**Battle Ready...Built Right!**



# Site 8 Visit Follow Up

---



---

***Battle Ready...Built Right!***



# Site 8 Visit Follow Up



***Battle Ready...Built Right!***



# Pease PFAS Risk Screening

## *Risk Assessment vs Health Assessment*

**USEPA**

### Risk Assessment

- Looks at *conditions* that could pose risk
- Focuses on current and foreseeable exposures
- Starts with standard exposure assumptions when evaluating site risk
- Follow-stages include site-specific considerations
- Estimates theoretical risk or hazard
- Helps determine the cleanup needed

**ATSDR**

### Health Assessment

- Looks at *impacts* on populations
- Identifies existing harmful exposures
- Recommends actions to protect public health
- Focuses on site-specific exposures, specific community health concerns, and health data
- Considers past exposures in addition to current and potential future exposures.
- Provides a more qualitative, less theoretical evaluation of possible public health hazards



# Pease PFAS Risk Screening

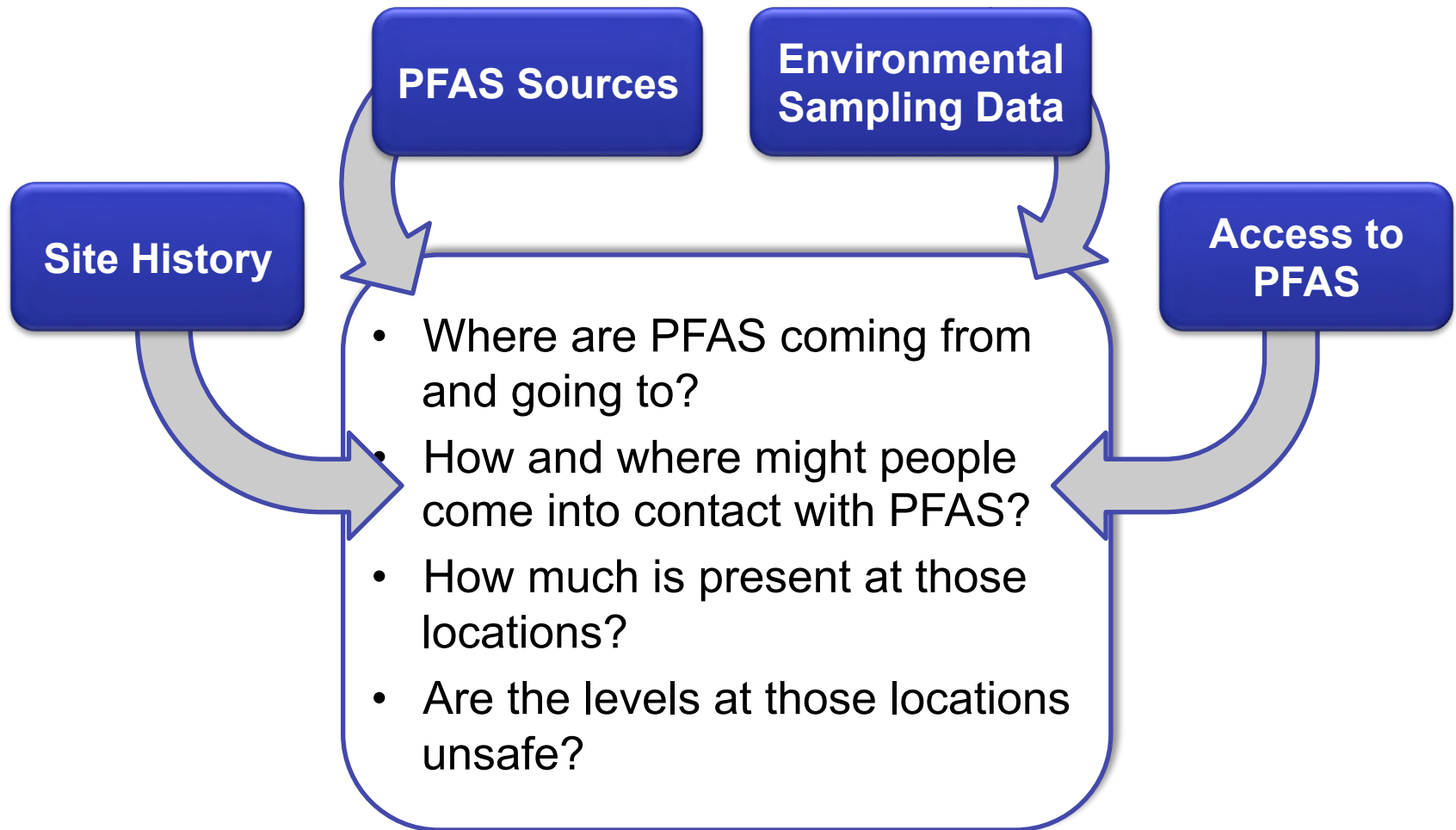





# Pease PFAS Risk Screening

Receptor & Exposure Pathway	Adult		Child	
	PFOA/PFOS	PFBS	PFOA/PFOS	PFBS
Child Recreator (wading - sediment ingestion/dermal contact)			0.609 mg/kg	609 mg/kg
Child Recreator (swimming - surface water ingestion)			2.03 µg/l	2,030 µg/l
Adult Recreator (swimming - surface water ingestion)	18.3 µg/l	18,300 µg/l		
Fish Consumption (in fish tissue)	0.00722 mg/kg	7.22 mg/kg	0.00521 mg/kg	5.21 mg/kg
Shellfish Consumption (in shellfish tissue)	0.00678 mg/kg	6.78 mg/kg	0.00559 mg/kg	5.59 mg/kg
Composite Worker (soil ingestion/dermal contact)	1.64 mg/kg	1,640 mg/kg		



# PFOS/PFOA Resources

---

**Roger Walton**  
Air Force Civil Engineer Center



# PFOS/PFOA Resources

---

- **DOD AFFF Report to Congress**
- **DOD Brief to House Armed Services Committee**
- **Interstate Technical and Regulatory Council**
- **EPA Cleanup Information (CLU-IN)**
- **U.S. Air Force Web Pages**
- **SERDP/ESTCP**
- **National Groundwater Association (*for fee*)**



# PFOS/PFOA Resources

---

- **DOD AFFF Report to Congress**
  - Released 03 Nov 2017
  - Available on DENIX
  - <https://www.denix.osd.mil/derp/home/documents/aqueous-film-forming-foam-report-to-congress/>
  - Explains DODs current approach to address PFOS/**PFOA**
    - Drinking Water
    - Defense Environmental Restoration Program
    - AFFF Replacement



# PFOS/PFOA Resources

---

- **DOD Brief to House Armed Services Committee**
  - Briefing held in March 2018
  - <https://www.denix.osd.mil/derp/home/documents/pfos-pfoa-briefing-to-the-hasc/>
  - **Official response to House Report 115-200**
    - Locations of PFOS/PFOA testing & results
    - Summary of mitigation actions
    - Process and timeline for long-term remediation
    - AFFF replacement



# PFOS/PFOA Resources

---

- **Interstate Technical and Regulatory Council**
  - <https://pfas-1.itrcweb.org/fact-sheets/>
  - **Naming Conventions and Physical and Chemical Properties**
  - **Regulations, Guidance, and Advisories**
  - **History and Use**
  - **Environmental Fate and Transport**
  - **Site Characterization Tools, Sampling Techniques, and Laboratory Analytical Methods**
  - **Remediation Technologies and Methods**



# PFOS/PFOA Resources

---

- **EPA Cleanup Information (CLU-IN)**
  - [https://clu-in.org/contaminantfocus/default.focus/sec/Per\\_and\\_Polyfluoroalkyl\\_Substances\\_\(PFASs\)/cat/Overview/](https://clu-in.org/contaminantfocus/default.focus/sec/Per_and_Polyfluoroalkyl_Substances_(PFASs)/cat/Overview/)
  - **Policy and Guidance**
  - **Chemistry and Behavior**
  - **Occurrence**
  - **Toxicology**
  - **Site Characterization and Analytical Methods**
  - **Remediation Technologies**



# PFOS/PFOA Resources

---

- **U.S. Air Force Pages**

- <http://www.afcec.af.mil/WhatWeDo/Environment/Perfluorinated-Compounds/>
- <http://www.afcec.af.mil/What-We-Do/Environment/Perfluorinated-Compounds/FAQs/>





# PFOS/PFOA Resources

---

- **SERDP/ESTCP**

- [https://www.serdp-estcp.org/Featured-Initiatives/Per-and-Polyfluoroalkyl-Substances-PFASs/\(language\)/eng-US](https://www.serdp-estcp.org/Featured-Initiatives/Per-and-Polyfluoroalkyl-Substances-PFASs/(language)/eng-US)
- **FAQs Regarding PFASs Associated with AFFF Use at U.S. Military Sites**
- <https://www.serdp-estcp.org/content/download/46768/437354/file/FAQ%20ER201574%20September%202017.pdf>



# PFOS/PFOA Resources

---

- **National Ground Water Association**
  - **\$150; free for members of NGWA**
    - Section 1 - Introduction (Free)
    - <http://www.ngwa.org/pubs/Documents/bookstore/pfas-doc-section1-overview.pdf>
    - Section 2 - Glossary
    - Section 3 - Human and Ecological Impact
    - Section 4 - Fate and Transport
    - Section 5 - Field Sampling and Analysis
    - Section 6 - Legal and Regulatory Issues
    - Section 7 - Risk Communication
    - Section 8 - Remediation and Treatment.



# Portsmouth Water Treatment

---

Brian Goetz  
City of Portsmouth



# Public Comment

---

**Goal:** Provide opportunity for members of the public to comment.

**Process:**

- Public members fill out a comment card if you wish to speak.
- 3 min limit per speaker.
- Speakers will be notified when they have 30 seconds remaining & at the 3 min mark.



# Open Discussion Time

---

- **Opportunity for RAB members to discuss additional topics**



# RAB Meeting Recap

---

- **Meeting Recap**
- **Next Steps**
- **Next meeting – TBD**



# Adjournment

---





# Pease Tradeport Water System Update

0/27/2018

Pease RAB Meeting



# Demonstration Project – Smith & Harrison Wells

- Active since September 2016
- Current flow rate = 400 gpm
- GAC Replacement in Filter 1 during week of March 26th



# Pease Tradeport Water System Activated Carbon Treatment Demonstration Project Sampling: May 24, 2018 Results

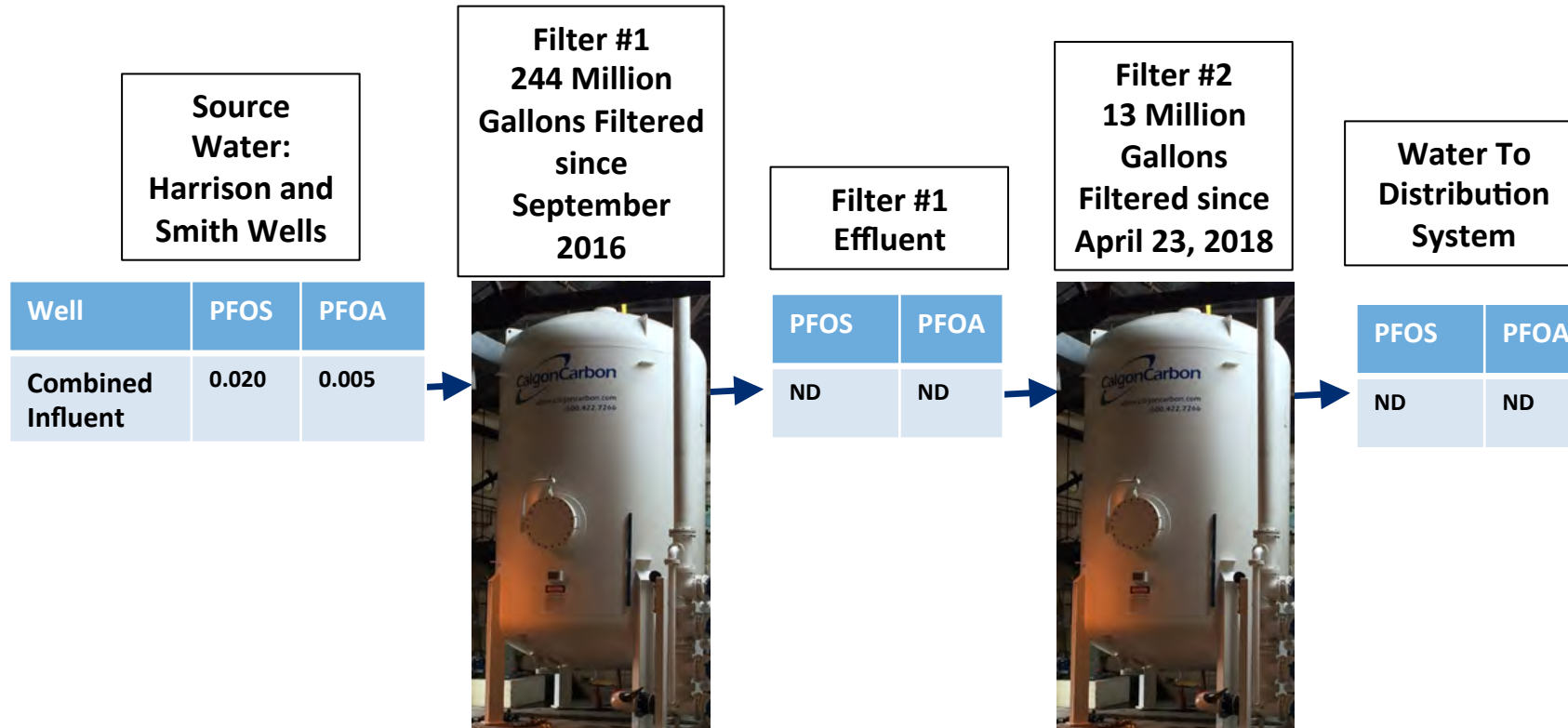

Notes: All samples in parts-per-billion (ppb)

ND = Non Detect

All samples collected by Weston & Sampson and analyzed by Maxxam Laboratory

# Haven Well Pilot (Sorbix LC1 vs Calgon F-400)



# Haven Well Treatment Pilot - total PFAS

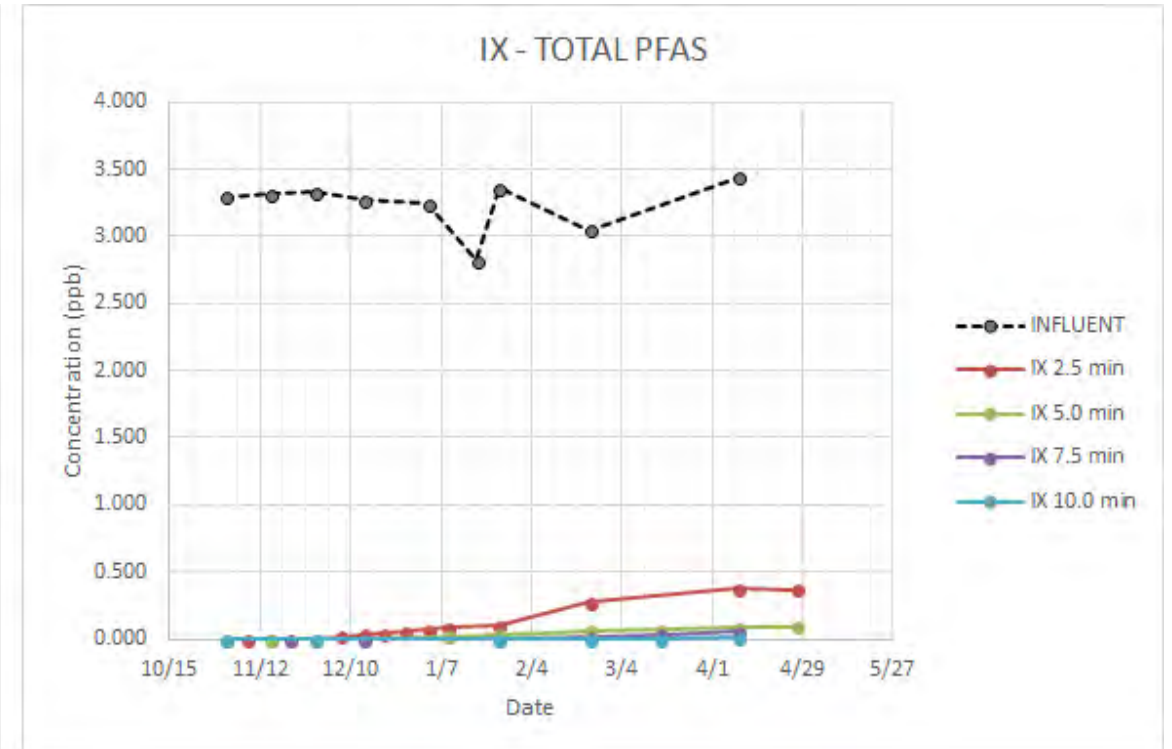
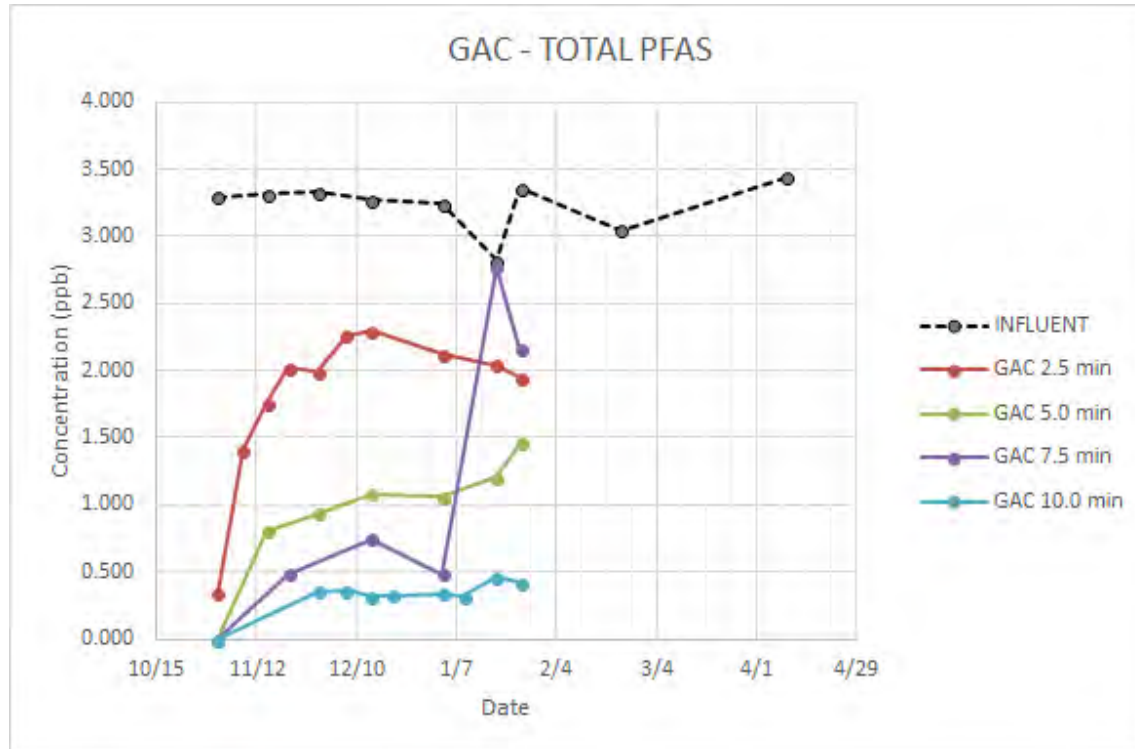

# Review of Other Public Water Systems

## Treating PFAS – current status

- Publically available data (mostly from water system websites) evaluated suggests that regarding PFAS compounds, the effected water systems are focused primarily on PFOA and PFOS relative to analytical/sampling efforts and reporting in publicly available documents.
- None of the 20 systems reviewed had test results readily available for the 23 PFAS compounds routinely sampled for by the City of Portsmouth and the Air Force under investigation activities at Pease.
- Most systems focus only on the compounds with an EPA health advisory, PFOA and PFOS.
- Only a few of the systems reviewed readily present their data providing the number of compounds, levels of detection, and the frequency of analysis.
- Currently, the City of Portsmouth is posting all of their sample results for all PFAS compound sampling to the City's website.

# Haven Pilot Conclusions

- Resin significantly outperforms GAC when raw water PFAS concentrations are high
- Resin removed short chain compounds better than GAC
- Less filter media changes necessary with resins than GAC
- Resins in combination with GAC will provide best long-term solution

# Proposed Final Treatment Schematic

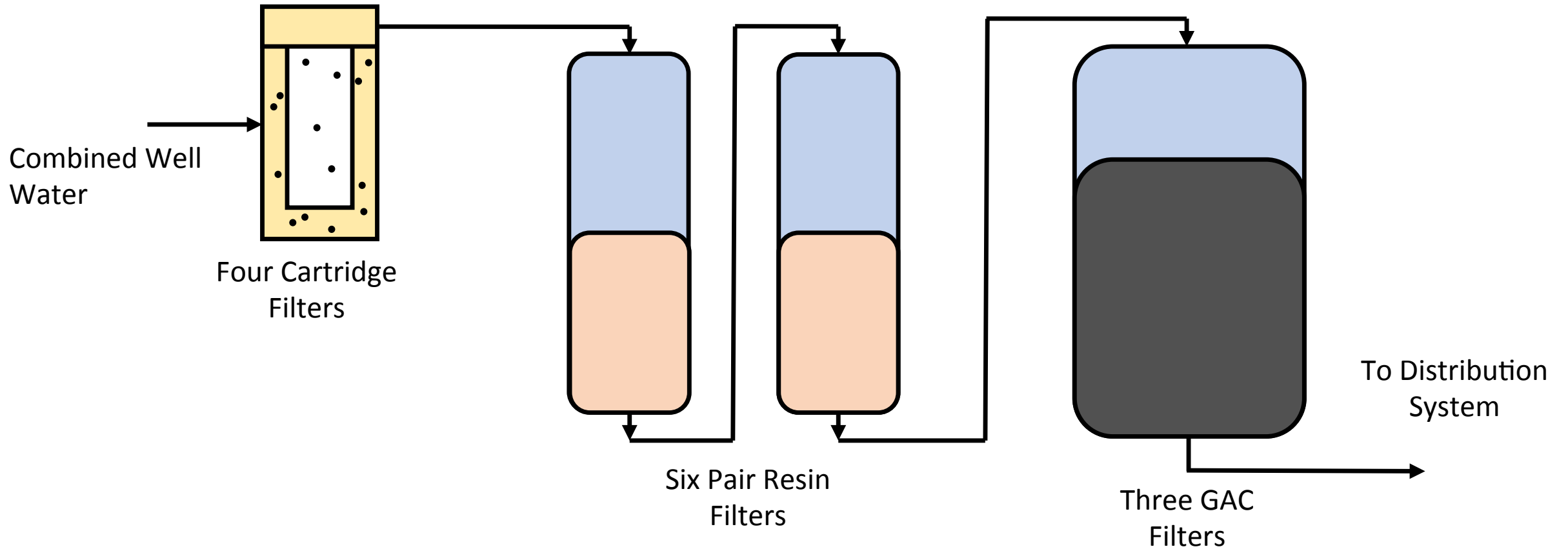



# Process Equipment

## Polishing GAC Filters

- Industry standard for treating PFAS

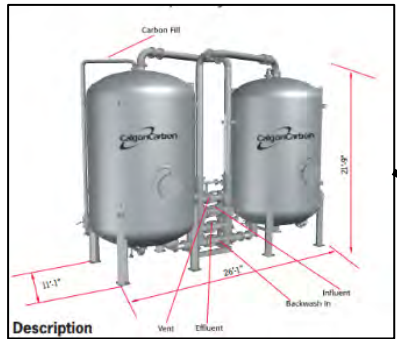

## Pretreatment Cartridge Filters

- Remove particulate matter

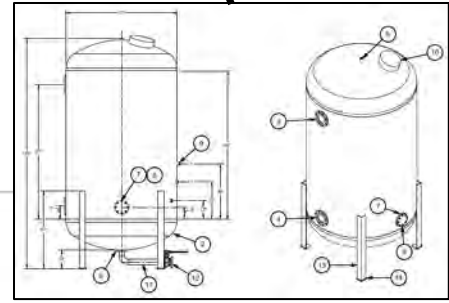
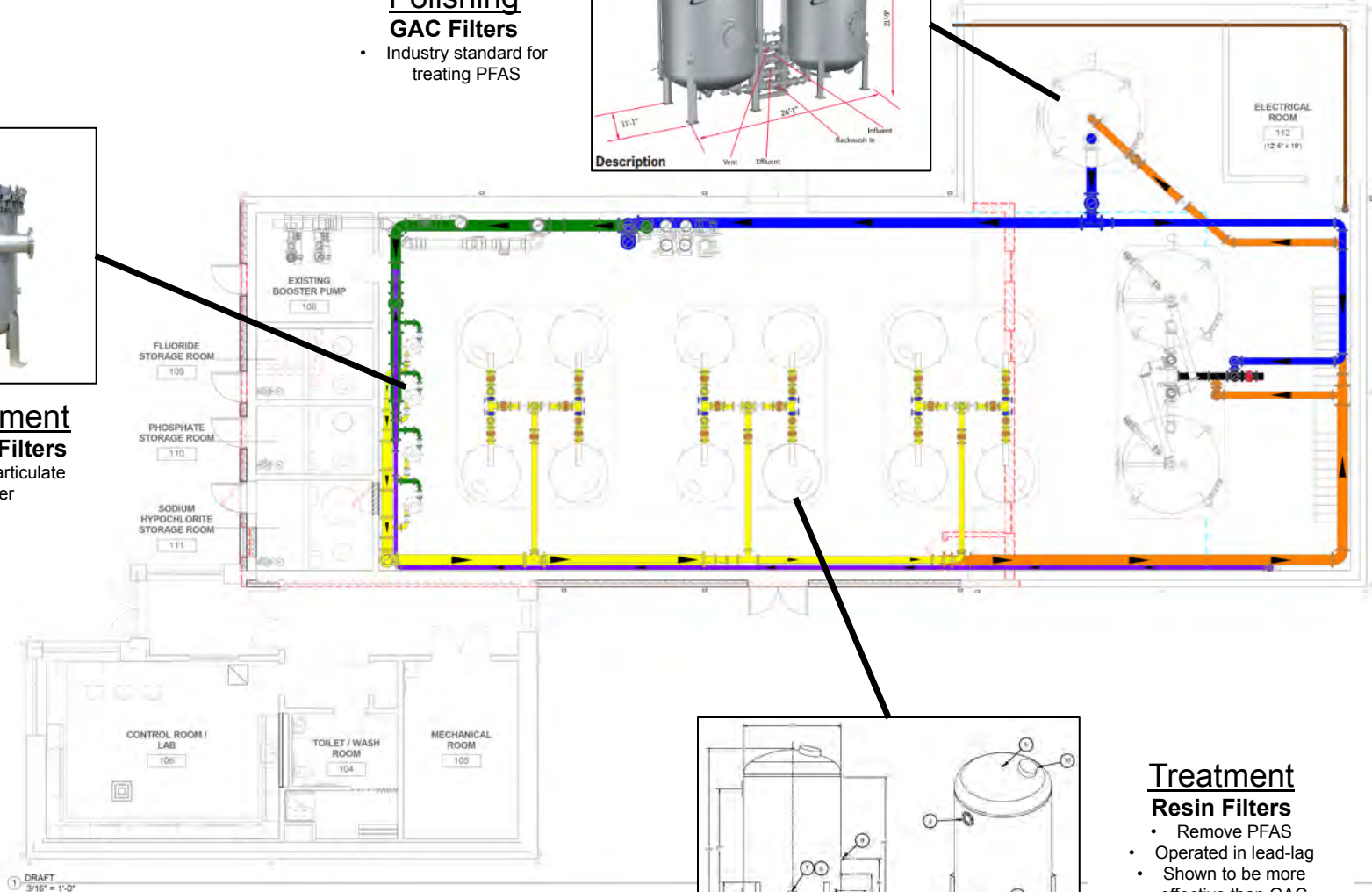

## Treatment Resin Filters

- Remove PFAS
- Operated in lead-lag
- Shown to be more effective than GAC



DRAFT

FOR CLARITY, THIS SHEET  
BEST VIEWED IN COLOR

DATE	04/23/18
REGISTERED PROFESSIONAL ENGINEER	
Author	
Designer	
Checker	
Drawn	
City	
State	
Country	

80% DESIGN  
NOT FOR CONSTRUCTION

CITY OF GRAFTON, NEW HAMPSHIRE DEPARTMENT OF PUBLIC WORKS GRAFTON ROAD DRINKING WATER TREATMENT PLANT	DRAFT
PROJECT NO. 2170715	CONTRACT
SCALE: 3/16" = 1'-0"	
DESIGNED BY	CHECKED BY
AUTHOR	DESIGNER
	CHECKER
	APPROVER

# Proposed Building Layout



② OVERALL BLDG RENDERING

SCALE: AS NOTED  
COPYRIGHT 2018 WESTON & SAMPSON



# Design Considerations

- Design for maximum flow rate of 1,200 gallons-per-minute (1.7 Million gallons-per-day)
- Additional pressure needed due to flow through four sets of filters prior to distribution system
  - Will require additional pumping, valving, metering and controls
- System operational setpoints will be more complex than the current GAC configuration
- Comprehensive water quality monitoring necessary to assure system water quality is meeting goals of treatment – We will continue to discuss with Air Force and regulators prior to reactivation of Haven Well

# Schedule

- 90% Plans and Specifications to AF – late July 2018
- Bidding – Fall/Winter 2018
- Award Contract – Early 2019

# Public Outreach

City of PORTSMOUTH NH | DEPARTMENT OF PUBLIC WORKS

## WATER

Quality & Status | Water Efficiency | New Service, Meters & Backflows | Billing | Information | Contact

City of Portsmouth > Public Works Home > Water > Pease Tradeport Water System

### PEASE TRADEPORT WATER SYSTEM

### WATER QUALITY AND RESPONSE TO PFAS COMPOUNDS

For information about the Portsmouth Water System's PFAS sampling, click [here](#)

The City of Portsmouth's Water Division has been actively working with the United States Air Force (Air Force), the United States Environmental Protection Agency (EPA), and the New Hampshire Department of Environmental Services (NHDES) in response to the detection of elevated levels of the unregulated contaminant perfluorooctane sulfonic acid (PFOS) from the Haven Well in 2014. This well was one of three wells that served the Pease International Tradeport water system. PFOS is one of a class of chemicals known as **Per- and polyfluoroalkyl substance** (often referred to as PFCs or PFAS). PFAS compounds are a diverse group of compounds resistant to heat, water, and oil. For decades, they have been used in hundreds of industrial applications and consumer products such as carpeting, apparels, upholstery, food paper wrappings, fire-fighting foams and metal plating. The contamination at the Haven Well has been attributed to the past use of **firefighting foam at the air base** and the air base's fire training center. Because the level of PFOS exceeded the **"provisional health advisory"** set by the EPA, the well was shut down and it has been off ever since. A number of actions have been taken by the project response technical team, which includes the City of Portsmouth, the **Air Force Civil Engineering Center**, the EPA, the **NHDES** and the **Pease Development Authority**. The following are key events and actions taken as part of the response.

# ANNUAL WATER QUALITY REPORT

PEASE WATER SYSTEM

PWSID 1951020

WATER TESTING PERFORMED IN 2017

